

Creation & Diagram :
Nicolas TERRY

Souris Mouse

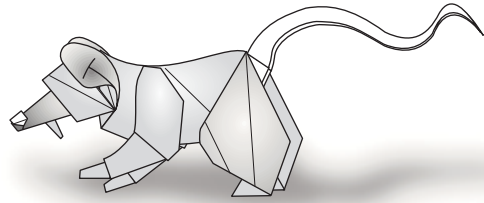

<http://www.passionorigami.com>

- Création # 79 / Date : 09/2005 1h00
- Niveau / Level : Intermédiaire / Intermediate
- Dimension (R= 0,6) :
Un carré de 20 cm donne un modèle de 12 x 4 cm.
A 20 cm square makes a 12 x 4 cm model.

Papier / Paper :
 Papier classique / Standard paper
 Papier sandwich / Tissue-foil
 Papier mouillé / Wet folding

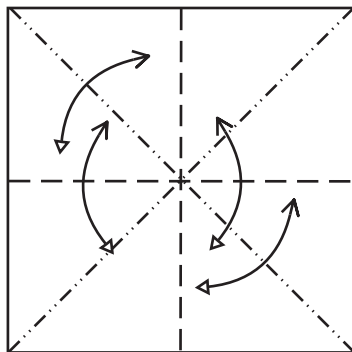
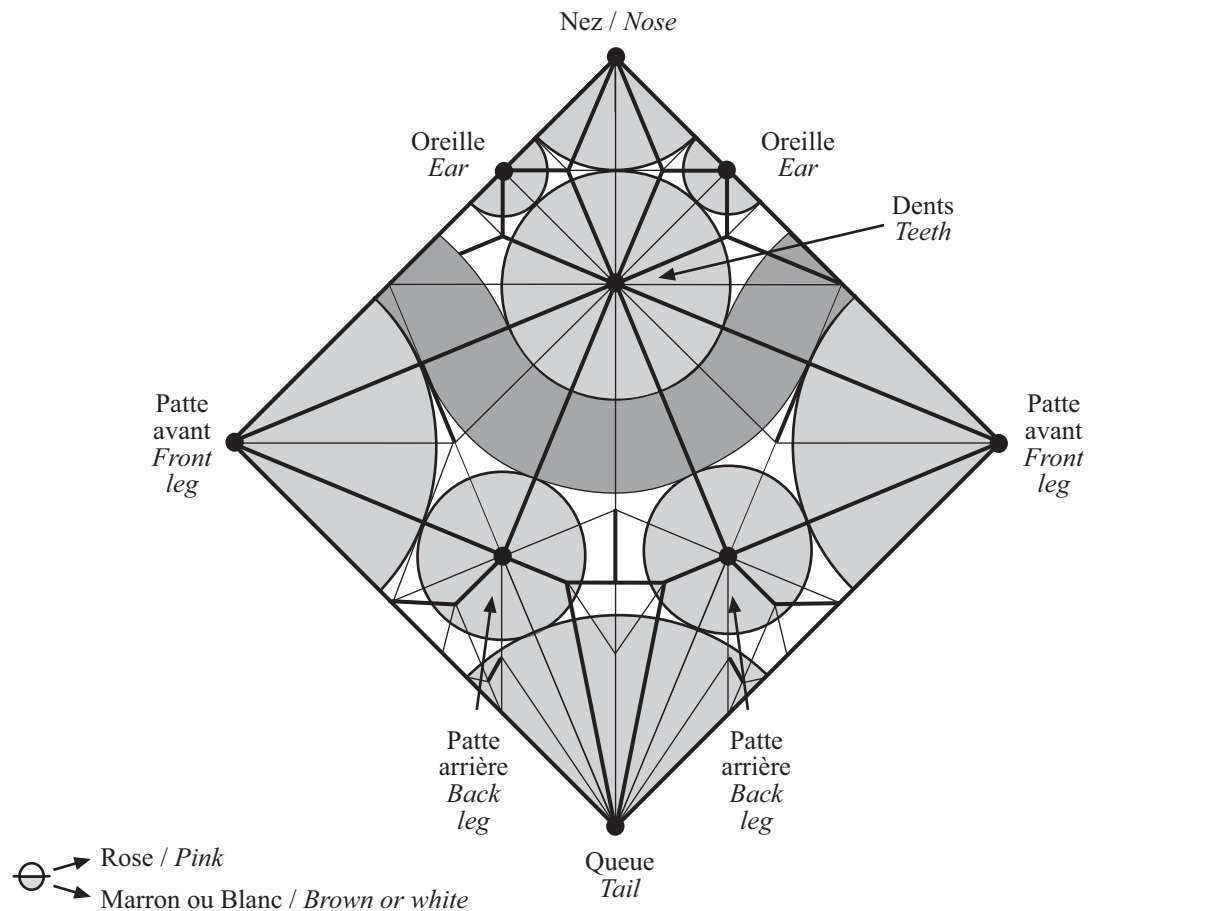

1. Plier les diagonales et les médianes et déplier.
Crease as shown above.

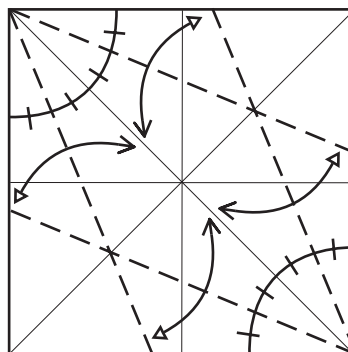

2. Plier les bissectrices et déplier.
Crease the angle bisectors.

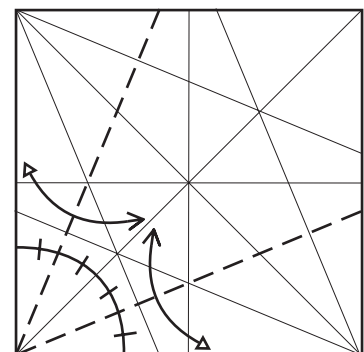

3. Plier les bissectrices et déplier.
Crease the angle bisectors.

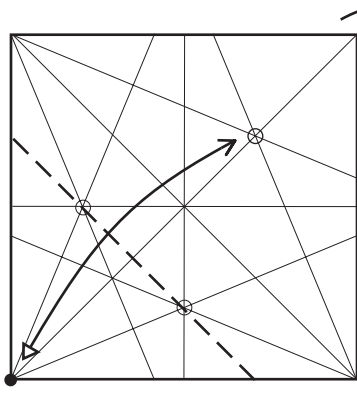

4. Plier et déplier. Retourner la feuille.
Fold and unfold. Turn the paper over.

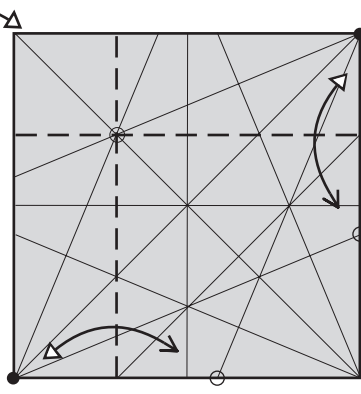

5. Plier et déplier.
Fold and unfold.

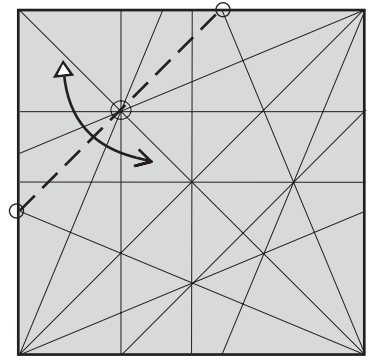

6. Plier et déplier.
Fold and unfold.

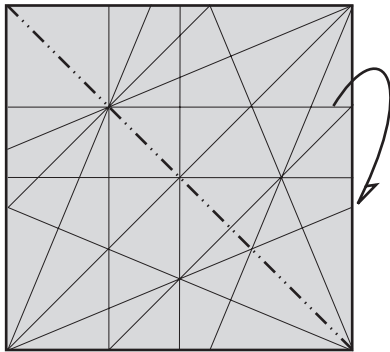

7. Plier en deux en montagne.
Mountain-fold in half.

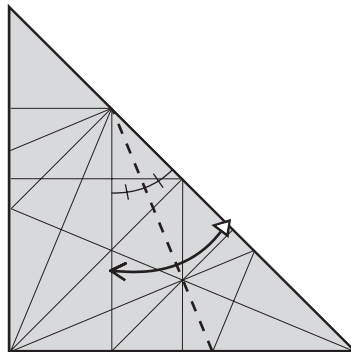

8. Plier la bissectrice et déplier.
Fold along angle bisector then unfold.

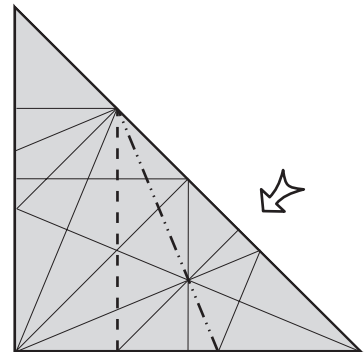

9. Pli aplati.
Squash-fold.

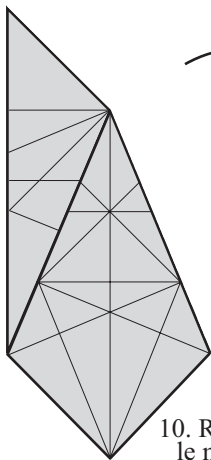

10. Retourner le modèle.
Turn the paper over.

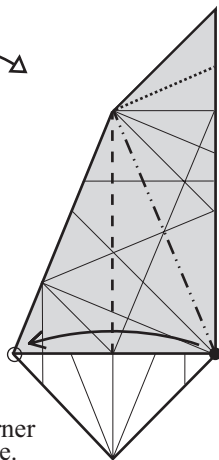

11. Pli pivot.
Swivel-fold.

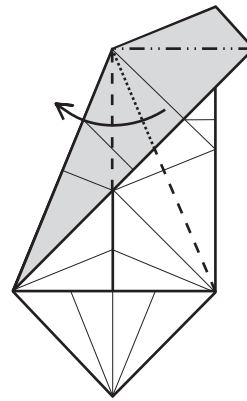

12. Pli pivot.
Swivel-fold.

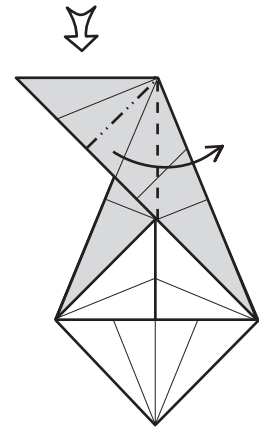

13. Pli aplati.
Squash-fold.

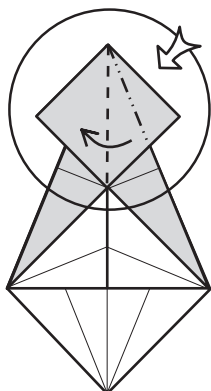

14. Pli aplati.
Squash-fold.

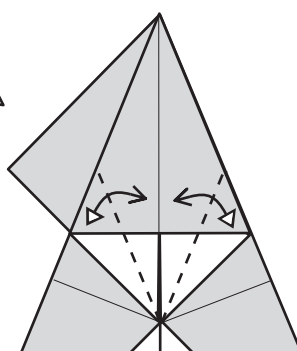

15. Plier les bissectrices et déplier.
Fold along angle bisector then unfold.

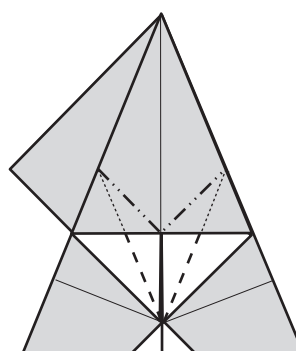

16. Deux plis inversés intérieurs.
Two reverse-fold.

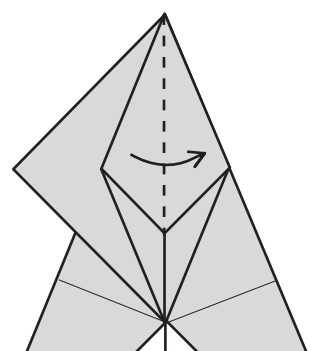

17. Plier le volet vers la droite.
Valley-fold the flap to the left.

14-17

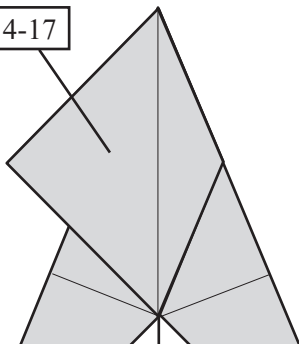

18. Répéter les étapes 14 à 17 à gauche.
Repeat steps 14 to 17 on the left.

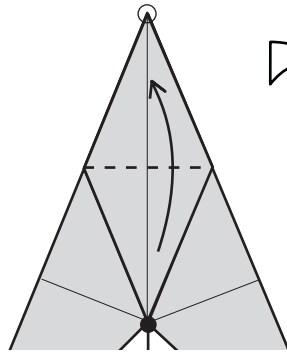

19. Plier le premier volet vers le haut.
Valley-fold.

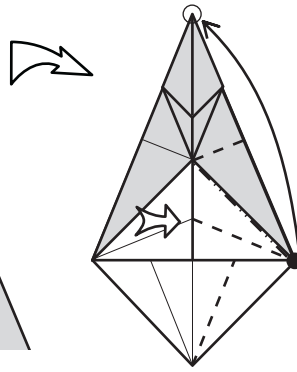

20. Pli pivot.
Swivel-fold.

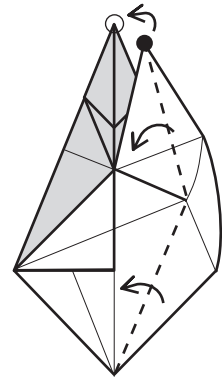

21. Pliage en cours.
Work in progress.

20-21

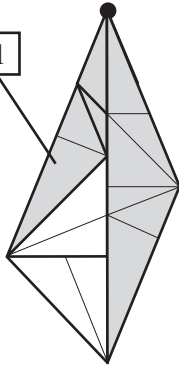

22. Répéter les étapes 20 à 21 à gauche.
Repeat steps 20 to 21 on the left.

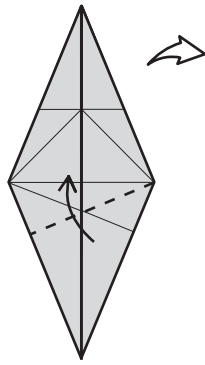

23. Plier selon les marques existantes.
Valley-fold following the existant marks.

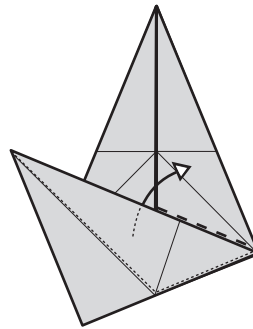

24. Sortir le volet caché.
Pull out the hidden flap.

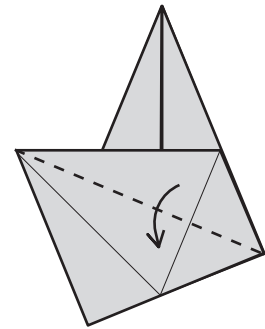

25. Rabattre le volet.
Valley-fold the flap.

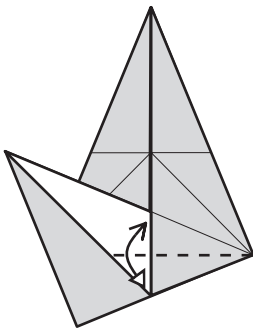

26. Plier et déplier.
Fold and unfold..

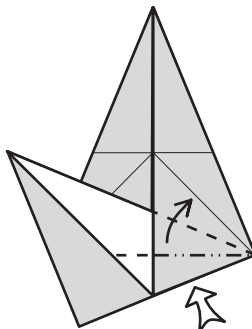

27. Pli aplati.
Squash-fold.

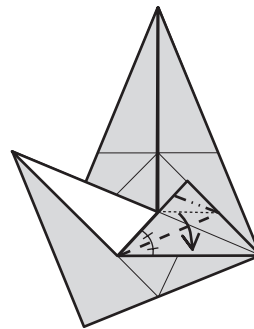

28. Pli pivot.
Swivel-fold.

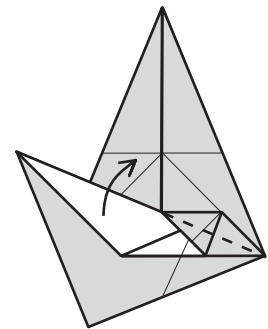

29. Déplier le volet.
Unfold the flap.

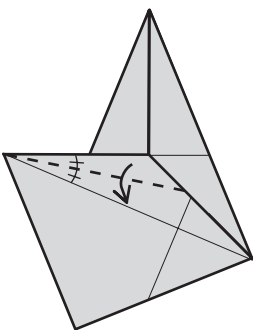

30. Plier la bissectrice.
Fold along angle bisector.

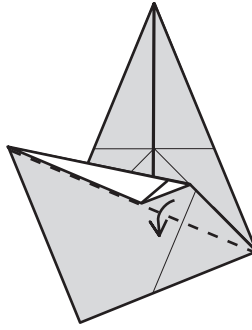

31. Plier la bissectrice.
Fold along angle bisector.

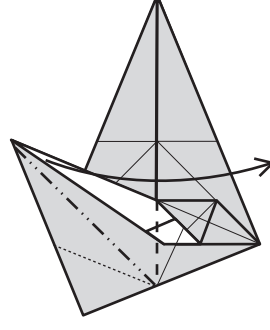

32. Pli pivot.
Swivel-fold.

24-31

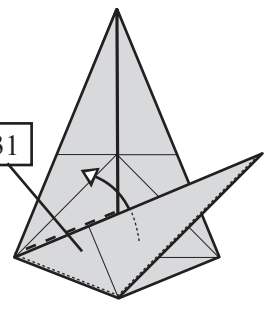

33. Répéter les étapes 24 à 31 à gauche.
Repeat steps 24 to 31 on the left.

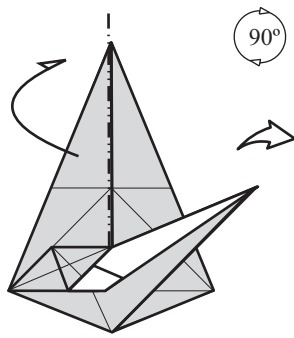

34. Pli pivot.
Swivel-fold.

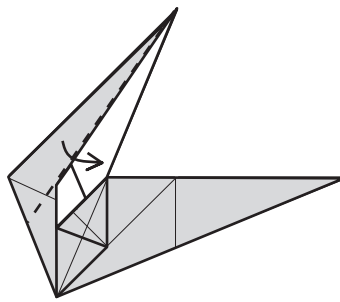

35. Pli vallée le long
du volet blanc.
*Valley-fold along
the white flap.*

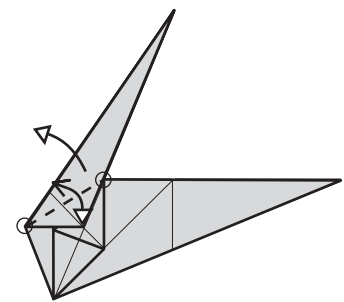

36. Plier et déplier. Puis
déplier jusqu'à l'étape 35.
*Valley-fold and unfold
then unfold until step 35.*

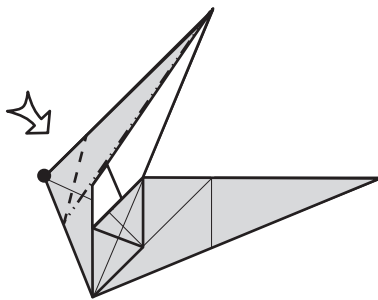

37. Pli enfoncé ouvert en utilisant les plis
réalisés aux étape 35 et 36.
*Open-sink using the creases
made in step 35 and 36.*

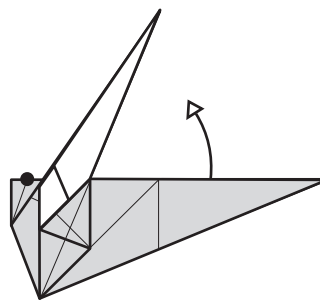

38. Remonter le volet arrière.
Unfold the back flaps.

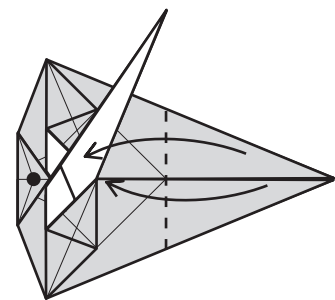

39. Plier les deux volets.
Valley-fold the two flaps.

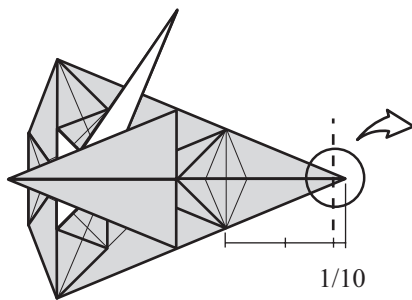

40. Plier et déplier.
Valley-fold and unfold..

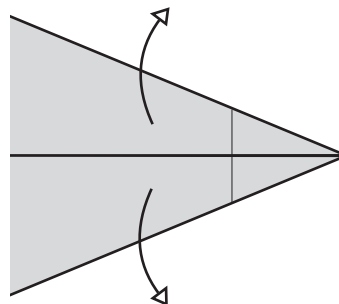

41. Ouvrir partiellement les volets.
Partially open the front flaps.

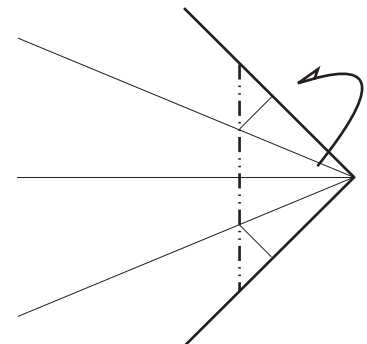

42. Plier en montagne le bout de la
pointe.
Mountain-fold the tip.

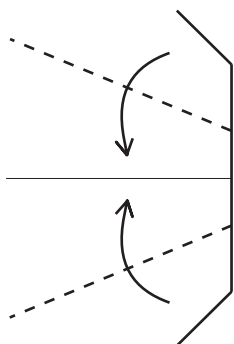

43. Replier
chaque volet.
Valley-fold the flaps.

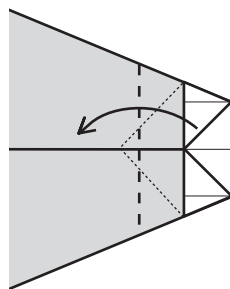

44. Plier à votre convenance
pour former le nez.
*Valley-fold to create
the noze.*

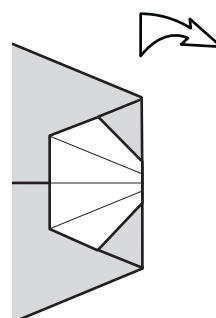

45. Le nez
est créé.
Finished noze.

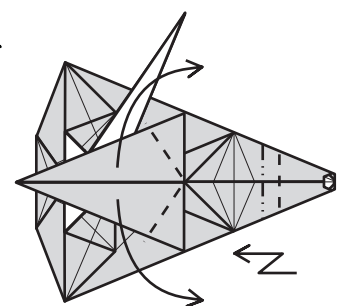

46. Repli simple pour former les yeux.
Plier chaque patte et vérifier leur position
finale à l'étape suivante.
*Pleat-fold to create the eyes. Then valley-
fold the front legs. Check the final position
at the step.*

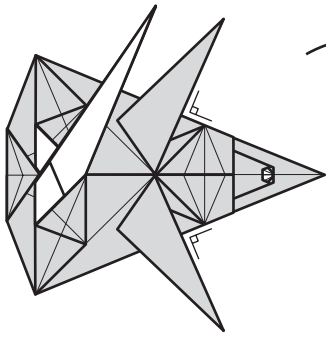

47. Tourner le modèle.
Turn the model over.

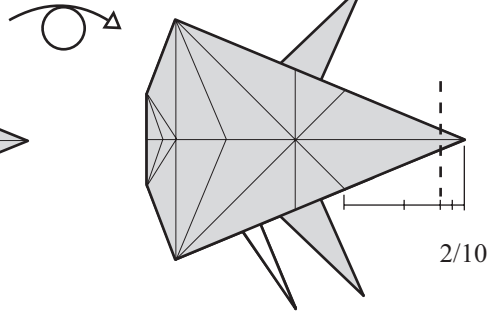

48. Plier la pointe pour former les dents.
Valley-fold the tip to create the teeth.

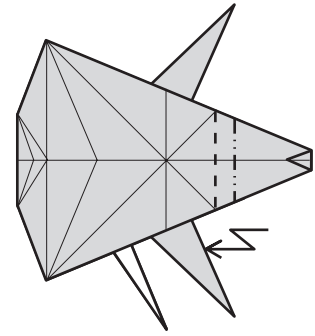

49. Réaliser un repli. Choisissez avec soin la place du pli montagne pour positionner correctement les dents par rapport au museau.
Pleat-fold. Choose with attention where the mountain-fold will be in order to place the teeth at the right place under the muzzle.

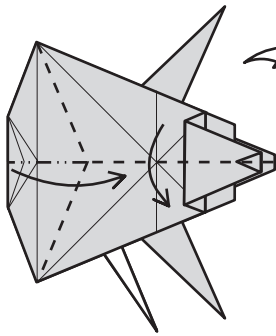

50. Refermer le modèle en incorporant un pli inversé intérieur.
Close the model incorporating a reverse-fold at the left side.

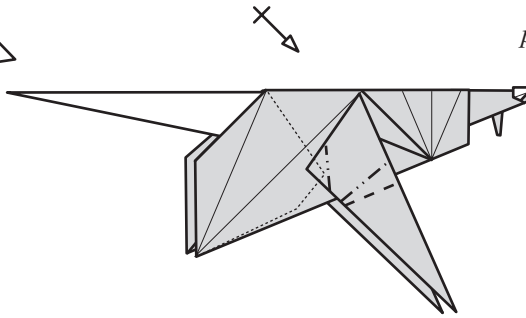

51. La base du rat est terminée. Plier en montagne pour arrondir les pattes avant. Réaliser un repli à votre convenance sur chaque patte.
Mountain-fold to round the legs. Pleat-fold also the legs.

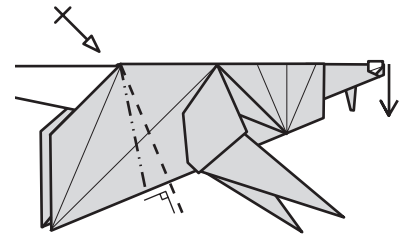

52. Réaliser un repli pour les pattes arrières à travers toutes les couches. Modeler la tête en abaissant le museau.
Pleat-fold the legs through all layers. Move down the muzzle.

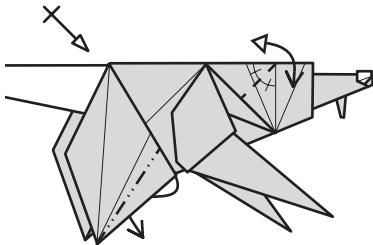

53. Réaliser un pli inversé intérieur sur les pattes arrières. Plier l'oreille et déplier.
Reverse-fold the back legs. Fold the ears and unfold.

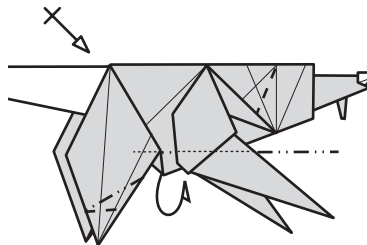

54. Rentrer la pointe du ventre à l'intérieur avec un pli montagne. Un repli créé la patte arrière. Plier l'oreille selon la bissectrice.
Mountain-fold the tip of the belly inside the model. Pleat-fold the back legs to create the feet. Valley-fold the ear along angle bisector.

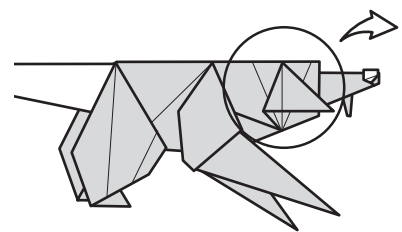

55. Zoom sur la formation de l'oreille.
Focus on the shape of the ear.

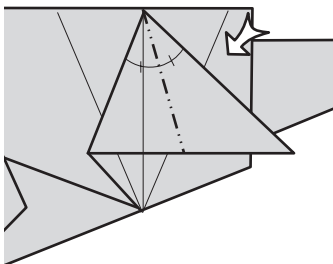

56. Pli aplati.
Squash-fold.

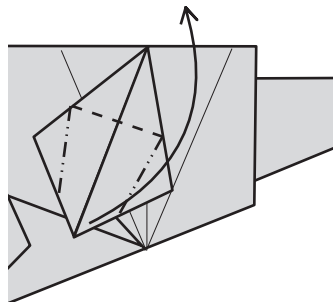

57. Réaliser une sorte de pli pétale. Il n'y a pas de points de référence.
Fold the ear using a kind of petal-fold. There is no reference points.

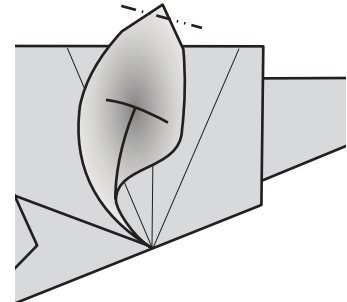

58. L'oreille est en 3D. Arrondir sa pointe.
The ear is in 3D. Round its tip.

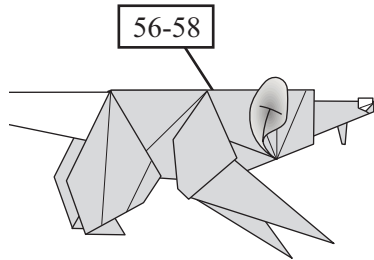

59. Répéter les étapes 56 à 58 sur l'autre oreille.
Repeat steps 56 to 58 on the other ear.

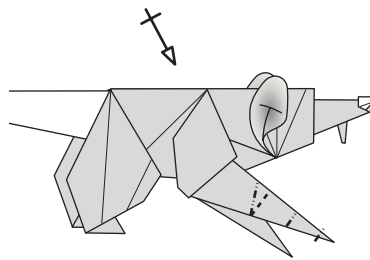

60. Modeler les pattes avant.
Shape the front legs.

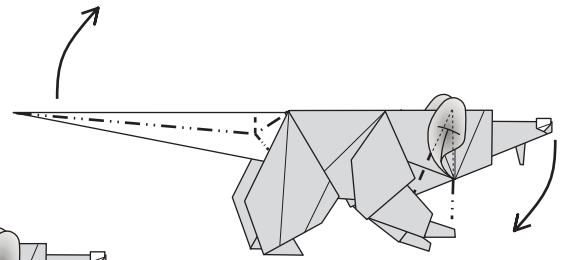

61. Double oreille de lapin sur la queue.
Repli double pour marquer la tête.
Double rabbit-ear fold on the tail. Crimp on the neck.

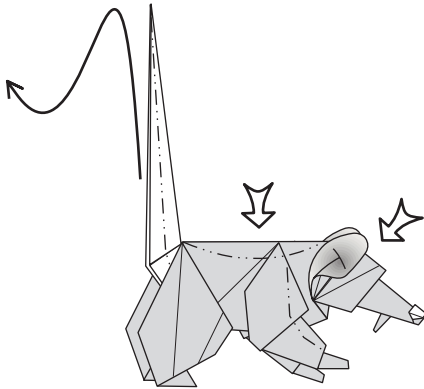

62. Modeler le rat.
Shape the rat.

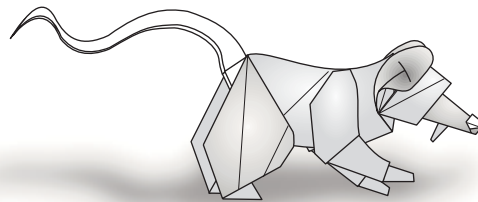

63. Le rat est terminé.
The rat is finished.

Défi : En utilisant un pli enfoncé complexe ouvert sur chaque pattes avant, faites apparaître 4 petits doigts. Puis transformer le nez en un nez plus visible. Enfin, redressez votre rat et vous obtiendrez un rat plus dans le style cartoon (cf ci-dessous).

Challenge : Use complex open sink on each arm to create 4 small fingers. Then change the actual nose in a more visible nose. You should obtain a new rat with a "cartoon style" (see photo).



Rat réaliste.
Realistic rat.



Rat cartoon.
Cartoon rat.

