

CRABE

-utiliser du gros papier (entre 90gr et 125gr) UNICOLORE
-ne pas hésiter à supprimer des étapes de prépliage (sauf 18-24)
-temps de pliage: environs 30 mn

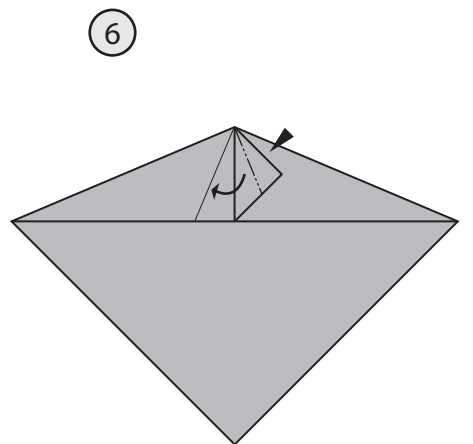
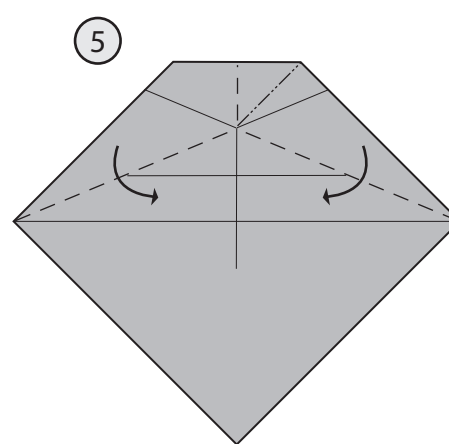
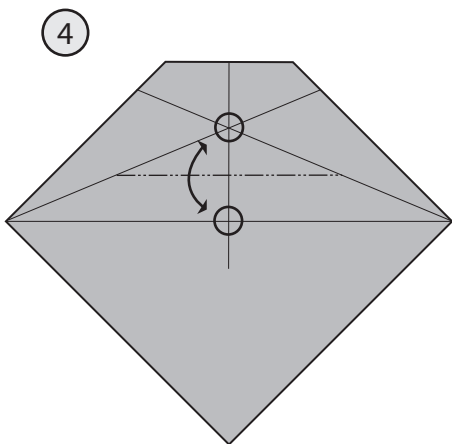
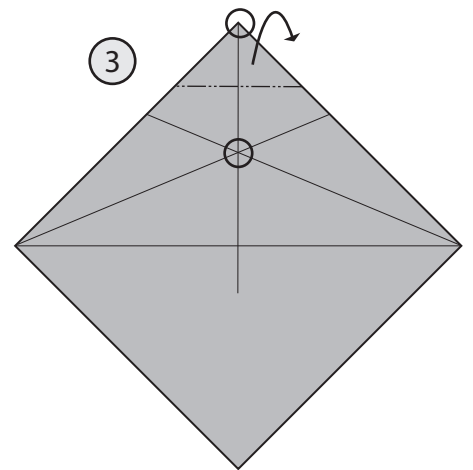
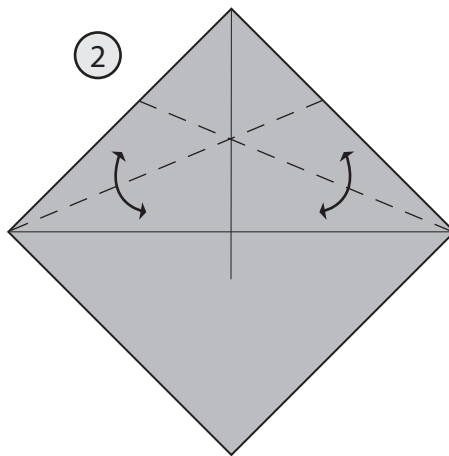
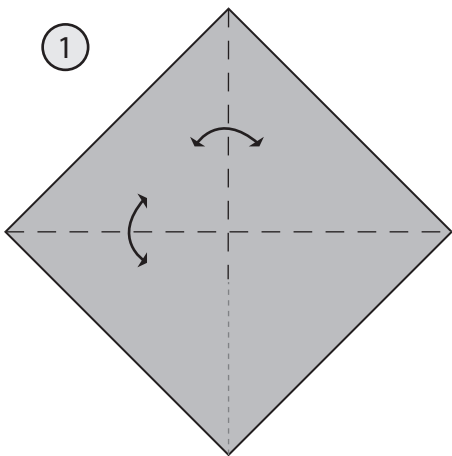

Oreille de lapin

Pli écrasé

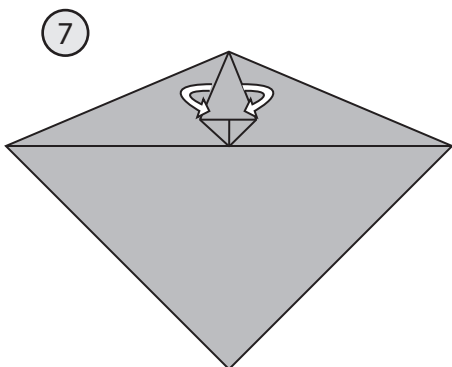

Résultat

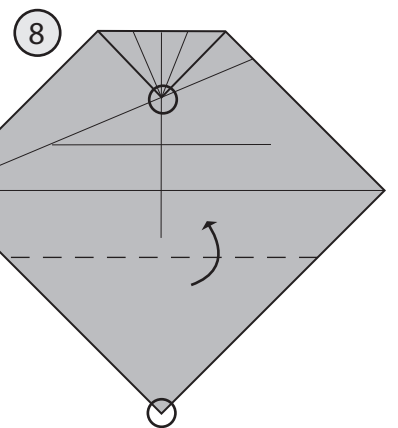
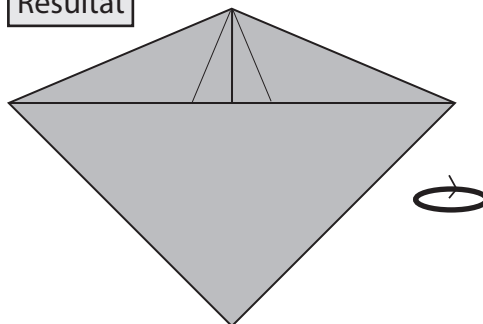

Inverser les plis pour faire passer le pli écrasé derrière

Déplier 5 à 7, retournez

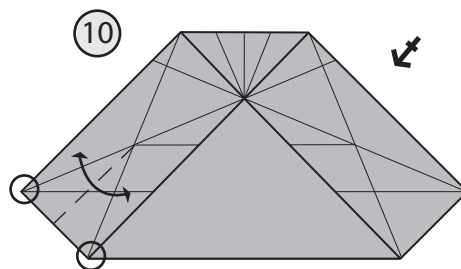
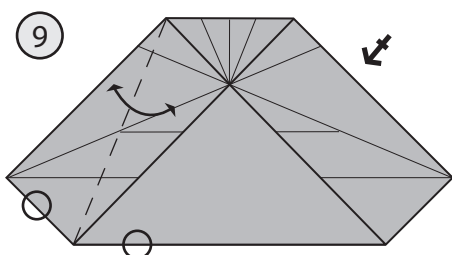

Marquer les plis
Déplier 8

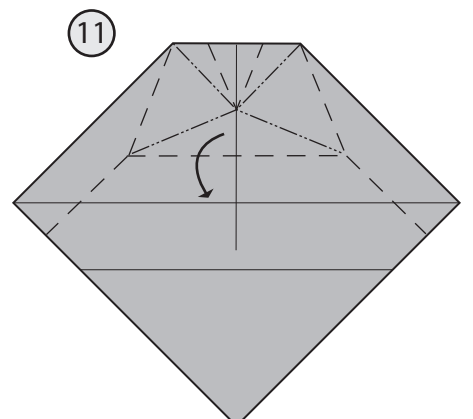

Tous les plis existent déjà

Résultat

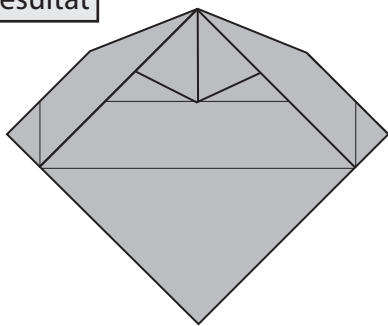

12

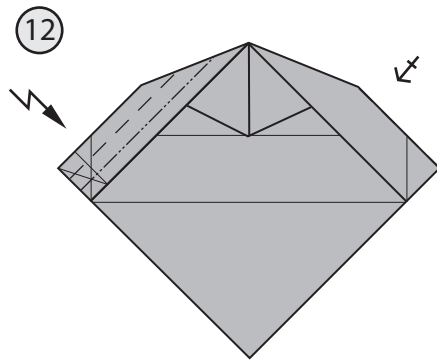

Enfoncez au tiers:

Référence

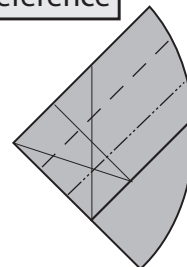

(pour trouver la référence en pliant)

13

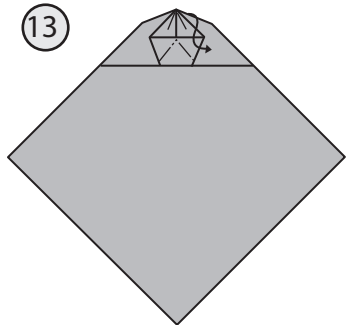

2 plis renversés en haut

14

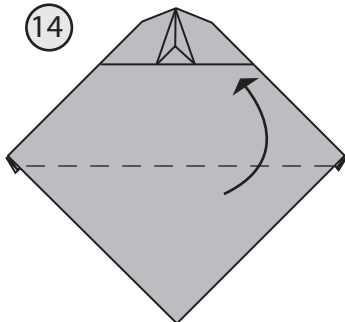

Pli vallée, aligné aux replis à l'arrière

15

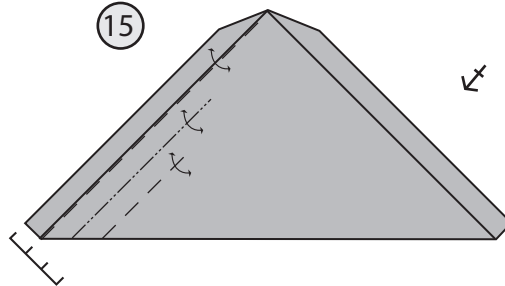

Reportez l'écart

16

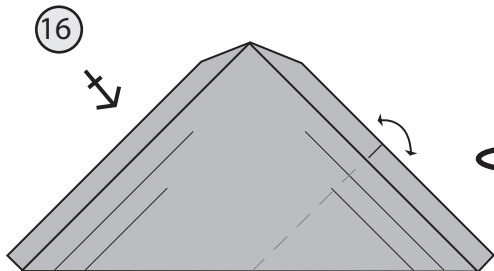

Marquer légèrement, retournez

17

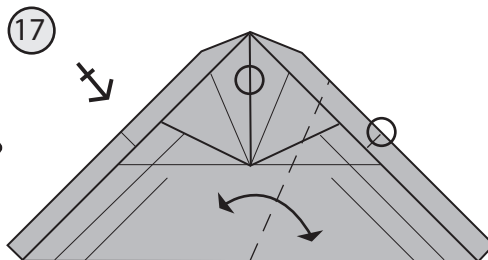

Marquez, dépliez 14

18

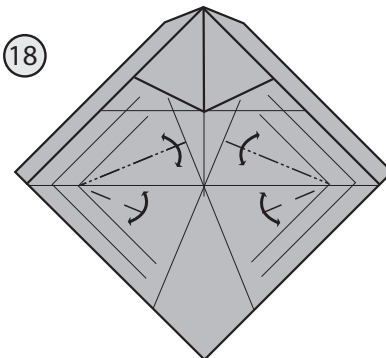

Marquez les bissectrices

19

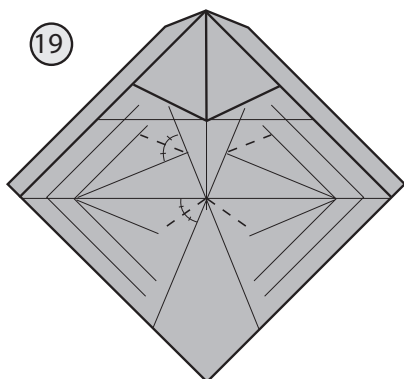

Marquez les bissectrices

20

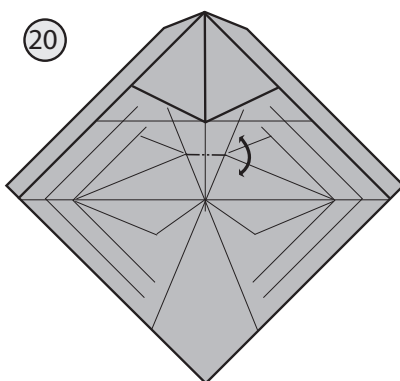

Pli montagne

21

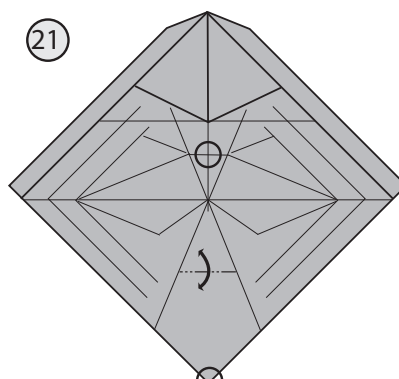

Pli montagne

22

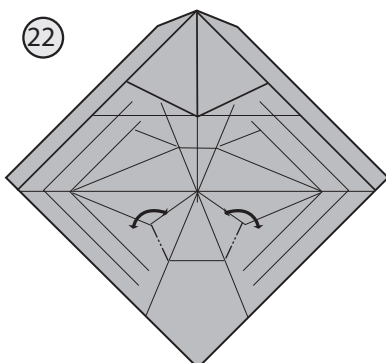

23

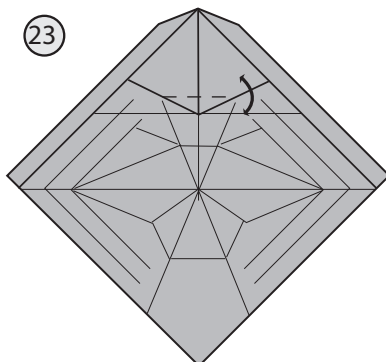

24

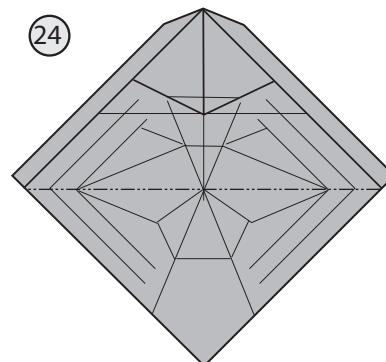

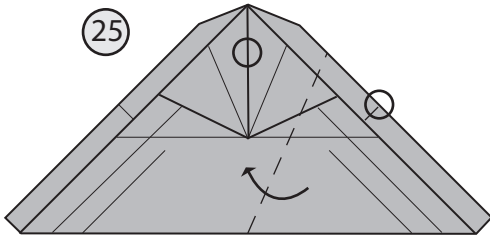

25
Aller ! On commence à plier pour de vrai !

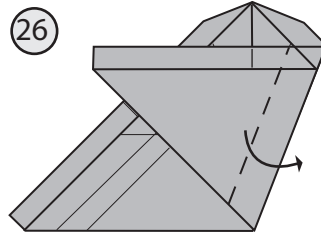

26
Pli aligné à la marque en dessous

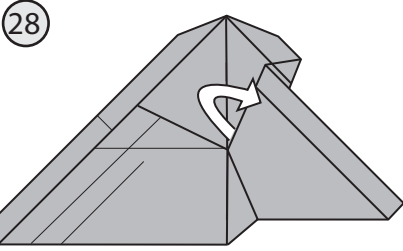
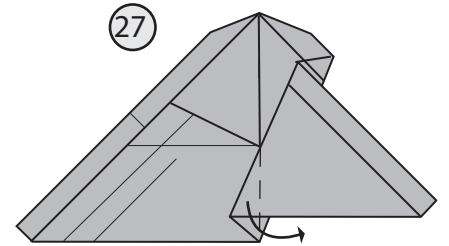

28
faire passer la couche devant

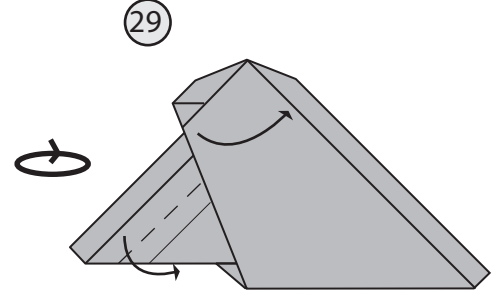
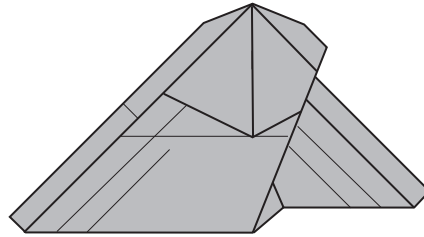

29
ouvrir le modèle vers la droite, si possible sans marquer de pli au centre.

En cours

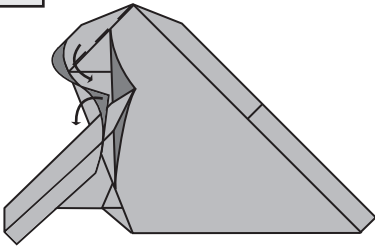

Faire pivoter pour aplattir

Résultat

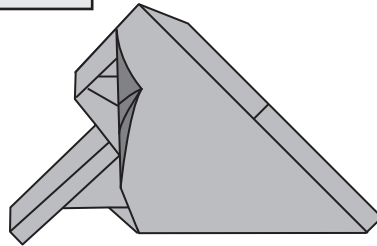

Seul le pan au centre n'est pas plat

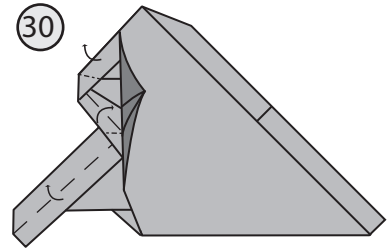

2 plis pivots

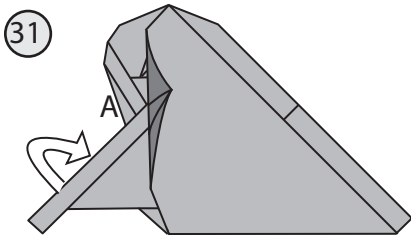

31
Sortir toute les couches

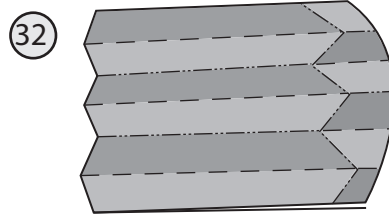

32
En A, il y avait un pli inversé simple: le transformer pour distinguer toutes les couches :



Résultat

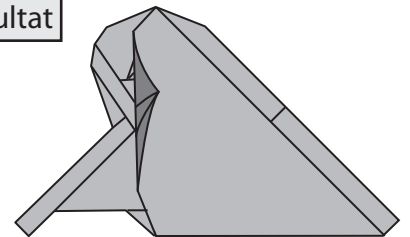

refermer

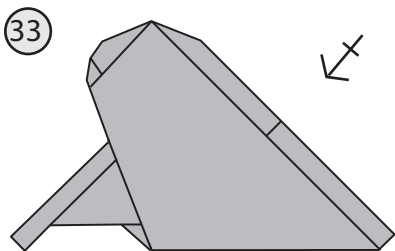

33
répéter 21-28

Résultat

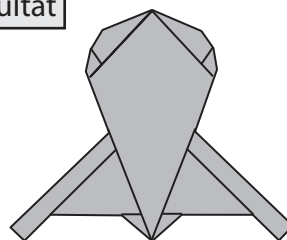

Face

Résultat

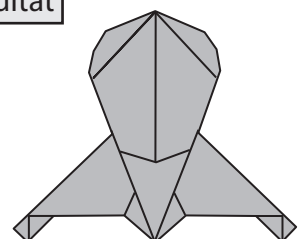

Pile

L'étape de la mort: séparer les deux jambes (pas facile à montrer en diagramme)

Tout au long de ces étapes, les plis de référence sont ceux marqués en 18-24

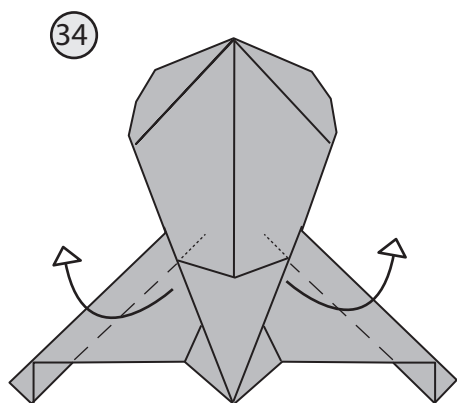

pli vallée, le plus loin possible, en dépliant la pointe du bas.

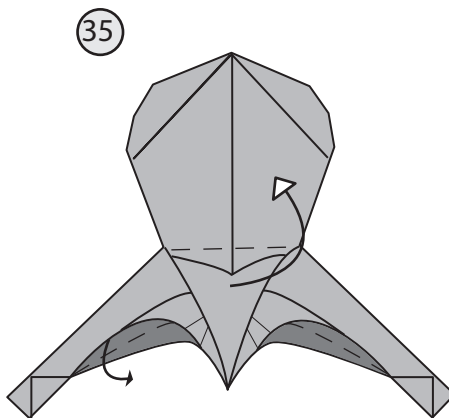

Commencez à plier suivant les plis marqués en 18-24. Ouvrir au maximum les première couches de la pointe du bas.

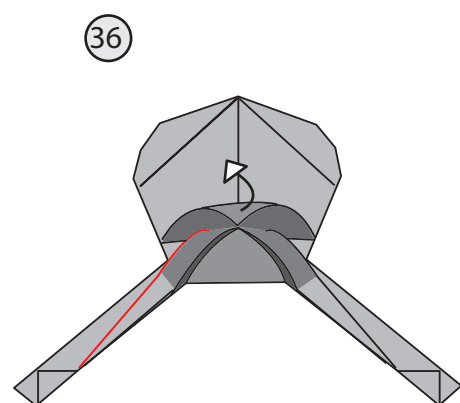

prolonger jusqu'au bout le pli montagne en rouge, en continuant d'ouvrir la partie supérieure de la pointe centrale

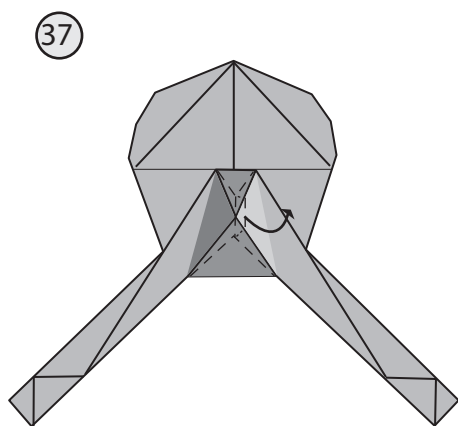

Normalement on obtient un modèle plat sauf une pyramide en 3D au centre...
Qu'on s'empresse d'aplatir

Résultat

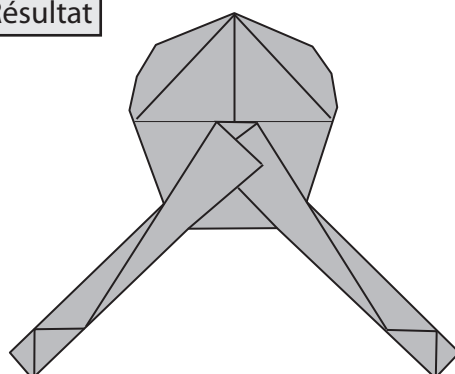

Pile...

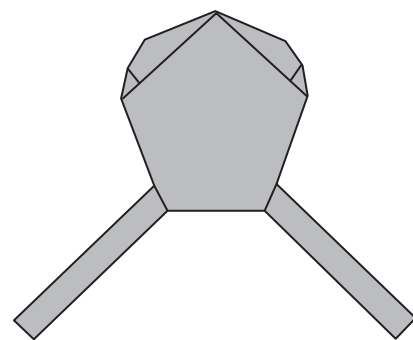

Face ...

Les pattes

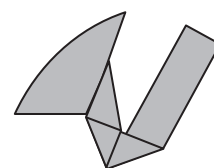
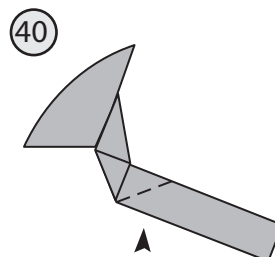
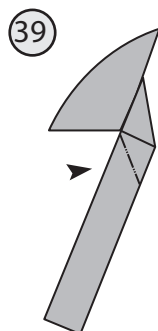
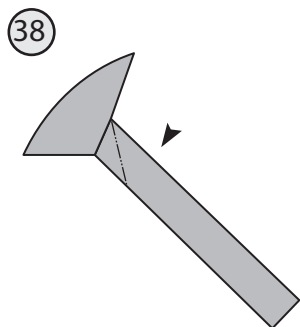

3 plis inversés à travers toutes les couches

La tête

41

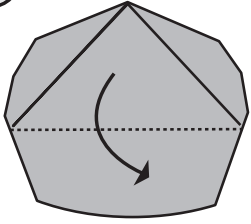

42

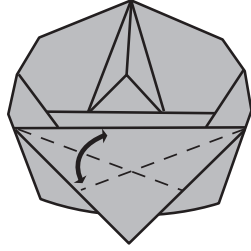

43

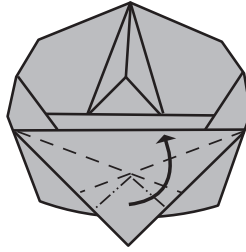

44

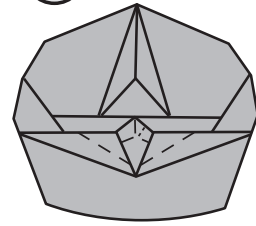

pli pour le diagramme:
évitez de le marquer en
pliant par dessous

écartez les 2 pans pour les
faire dépasser, en intégrant
une oreille de lapin.

Résultat

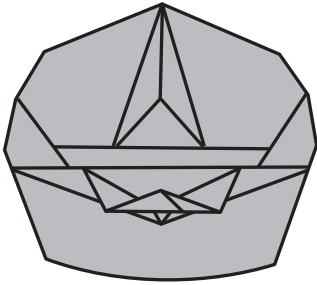

Ouvert

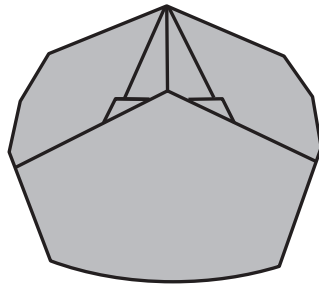

Refermé

Les pinces

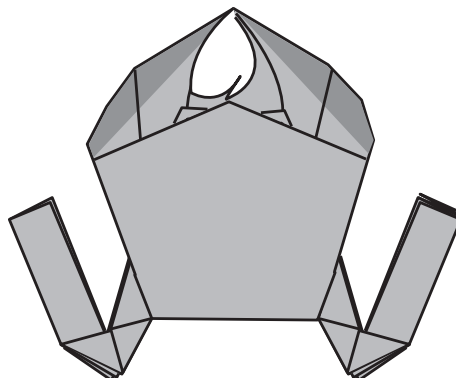
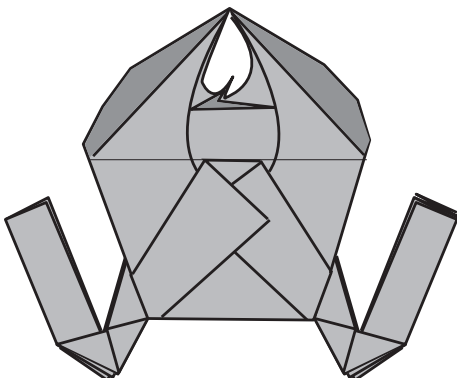
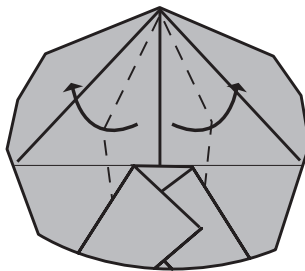
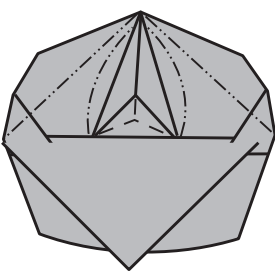

Reste à modeler

Kaze